

■ **INTRODUCTION**

The CE6260 Series are a group of positive voltage regulators manufactured by CMOS technologies with high ripple rejection, extremely low power consumption and low dropout voltage, which provide large output currents even when the difference of the input-output voltage is small. Each of the CE6260 series consists of a high-precision voltage reference, an error correction circuit, and a current limited output driver. Thus the series are very suitable for the battery-powered equipments, such as Portable/Palm computers, Portable consumer equipments, industry equipments and so on, which want to prolong the using life of the battery.

■ **APPLICATIONS**

- Battery powered systems
- Portable instrumentations
- Reference Voltage Sources

■ **BLOCK DIAGRAM**

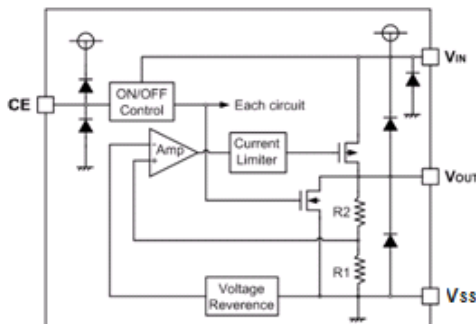

■ **FEATURES**

- Output Current: 500mA (Typ.)
- Quick Start-Up: 50μs (Typ.)
- Built-in Quick Discharge Circuit
- Output Voltage Range: 0.9V~5.0V (selectable in 0.1V steps)
- High Accuracy: ±2% (Typ.)
- Dropout Voltage: 120mV@100mA (3.0V Typ.)
- Excellent Line Regulation: 0.1%/V
- Built-in Current Limiter
- Built-in Short Circuit Protection
- Static safety, 2KV@HBM
- TC: 100ppm/°C
- Low ESR Capacitor: Ceramic Compatible

- Radio control systems
- Portable/Palm computers
- Portable consumer equipments

■ **ORDER INFORMATION**

CE6260①②③④

DESIGNATOR	SYMBOL	DESCRIPTION
①	A	Standard
	B	With Shutdown Function
②③	Integer	Output Voltage (0.9~5V) e.g:3.0V=②:3, ③:0
④	M	Package:SOT-23-3/5
	P	Package:SOT-89-3/5

■ **PIN CONFIGURATION** (Pin output sequence can be ordered by customer)

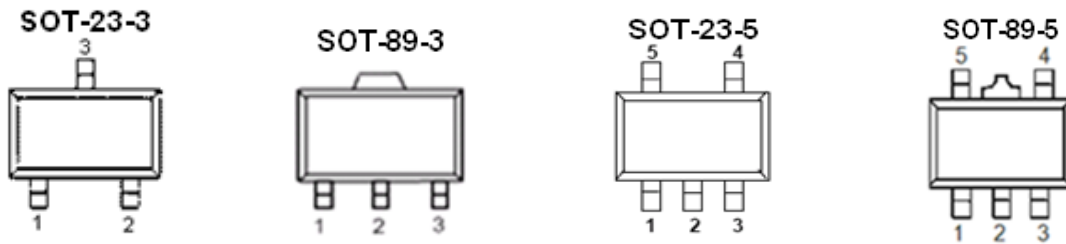

PIN NUMBER			PIN NAME	FUNCTION
SOT-23-3	SOT-89-3			
M	P	PT		
1	1	2	V _{SS}	Ground
2	3	1	V _{OUT}	Output
3	2	3	V _{IN}	Power input

SOT-23-5

PIN NUMBER	SYMBOL	FUNCTION
1	V _{IN}	Power Input Pin
2	V _{SS}	Ground
3	CE	Chip Enable Pin
4	NC	No Connection
5	V _{OUT}	Output Pin

SOT-89-5

PIN NUMBER	SYMBOL	FUNCTION
1	V _{OUT}	Output Pin
2	V _{SS}	Ground
3	NC	No Connection
4	CE	Chip Enable Pin
5	V _{IN}	Power Input Pin

■ **ABSOLUTE MAXIMUM RATINGS**

(Unless otherwise specified, Ta=25°C)

PARAMETER	SYMBOL	RATINGS	UNITS
Input Voltage	V _{IN}	V _{SS} -0.3~V _{SS} +8	V
Output Current	I _{OUT}	600	mA
Output Voltage	V _{OUT}	V _{SS} -0.3~V _{IN} +0.3	V
Power Dissipation	SOT-89	Pd	500
	SOT-23	Pd	250
Operating Temperature	T _{Opr}	-40~+85	°C
Storage Temperature	T _{stg}	-40~+125	°C
Soldering Temperature & Time	T _{solder}	260°C, 10s	

■ ELECTRICAL CHARACTERISTICS

CE6260 Series (V_{IN}=V_{OUT}+1V, C_{IN} = C_{OUT} = 3.3μF, Ta=25°C, unless otherwise specified)

PARAMETER	SYMBOL	CONDITIONS	MIN	TYP	MAX	UNITS	
Output Voltage	V _{OUT(E)} (Note 2)	I _{OUT} =100mA, V _{IN} =V _{OUT} +1V, V _{IN} ≥2V	1.5V<V _{OUT} ≤5.0V	V _{OUT} *0.98	V _{OUT} (Note 1)	V _{OUT} *1.02	V
			0.9V≤V _{OUT} ≤1.5V	V _{OUT} -0.03	V _{OUT}	V _{OUT} +0.03	V
Supply Current	I _{SS}	V _{CE} =V _{IN} =V _{OUT} +1V		6		μA	
Shutdown Current	I _{SHDN}	—		0.1	1.0	μA	
Output Current	I _{OUT}	V _{IN} ≥2V, V _{IN} =V _{OUT} +1V	500			mA	
Dropout Voltage (Note 3)	V _{diff1}	I _{OUT} =100mA		120		mV	
	V _{diff2}	I _{OUT} =500mA		650		mV	
Load Regulation	ΔV _{OUT}	V _{IN} =V _{OUT} +1V, 1mA≤I _{OUT} ≤500mA		70		mV	
Line Regulation	$\frac{\Delta V_{OUT}}{\Delta V_{IN} * V_{OUT}}$	I _{OUT} =100mA V _{OUT} +1V≤V _{IN} ≤6V		0.1		%/V	
Output Voltage Temperature Characteristics	$\frac{\Delta V_{OUT}}{\Delta T * V_{OUT}}$	I _{OUT} =40mA -40≤T≤+85		100		ppm/ °C	
Power Supply Ripple Rejection	PSRR	I _{OUT} =100mA f = 1KHz		40		dB	
Short Current	I _{Short}	V _{OUT} =V _{SS}		30		mA	
Current Limit	I _{Lim}	V _{IN} = V _{OUT} +1V		650		mA	
Input Voltage	V _{IN}	—	2.0		6.0	V	
CE "High" Voltage	V _{CE} "H"		1.5		V _{IN}	V	
CE "Low" Voltage	V _{CE} "L"				0.3	V	

NOTE:

1. V_{OUT}: Specified Output Voltage.
2. V_{OUT} (E) : Effective Output Voltage (I.e. The Output Voltage When V_{IN} = (V_{OUT} +1.0V) And Maintain A Certain I_{OUT} Value).
3. V_{diff}: The Difference Of Output Voltage And Input Voltage When Input Voltage Is Decreased Gradually Till Output Voltage Equals To 98% Of V_{OUT} (E); When V_{OUT}<2.0V, V_{IN}≥2.0V Should be Guaranteed.

■ TYPICAL APPLICATION CIRCUITS

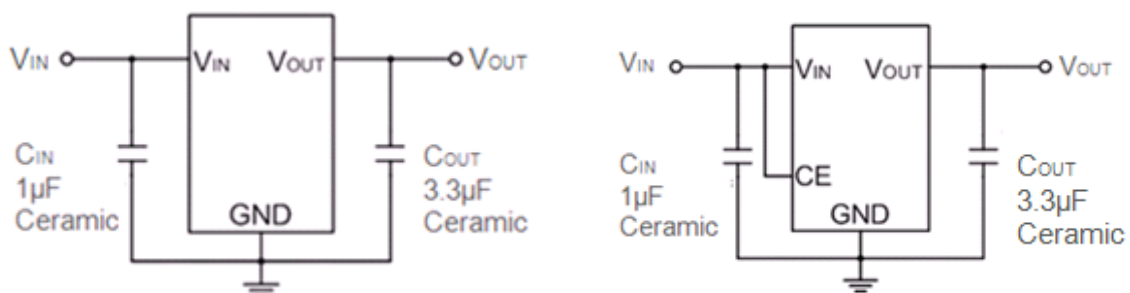

■ **TYPICAL PERFORMANCE CHARACTERISTICS (CE6260B30P, for instance)**

(1) **Output Voltage vs. Input Voltage**

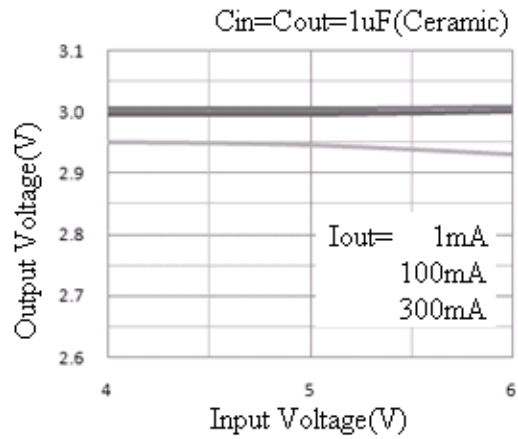
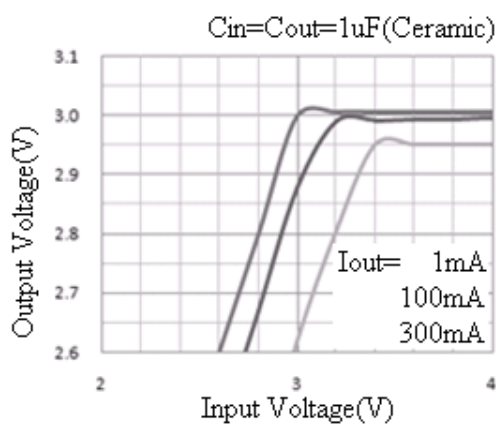

(2) **Input Transient Response 1**

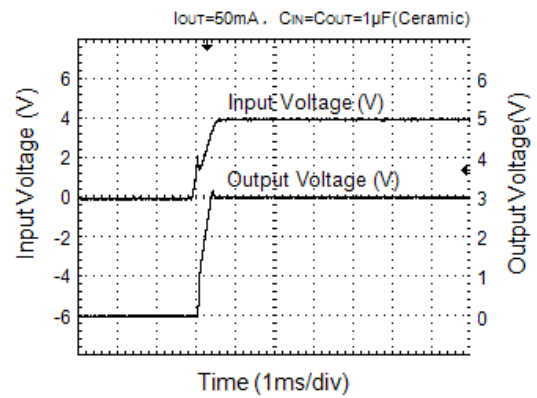
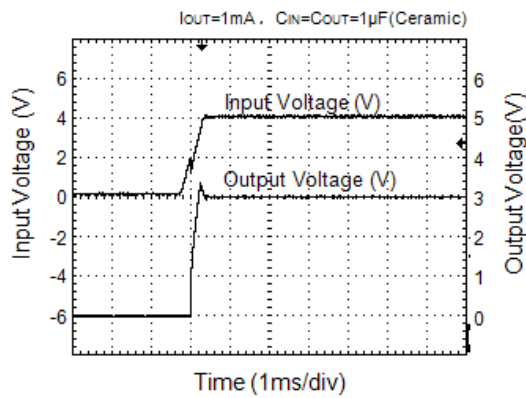

(3) **Input Transient Response 2**

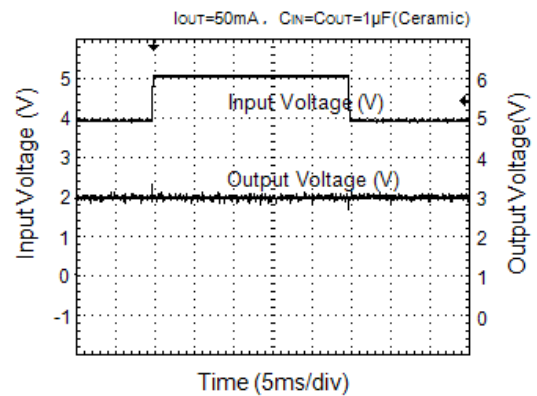
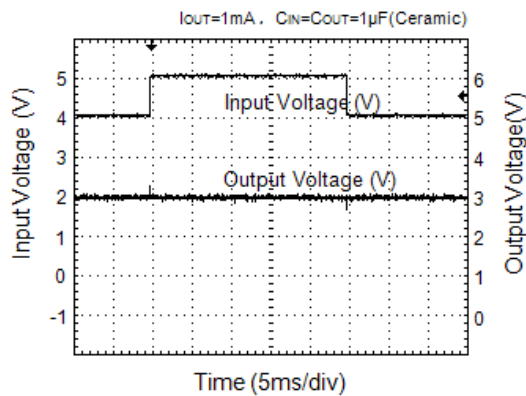

(4) CE Shutdown Response

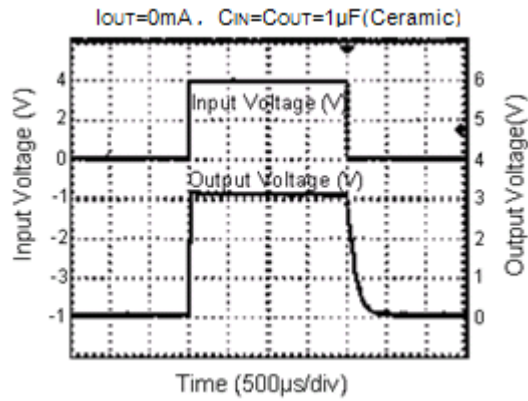

(5) Output Voltage vs Temperature

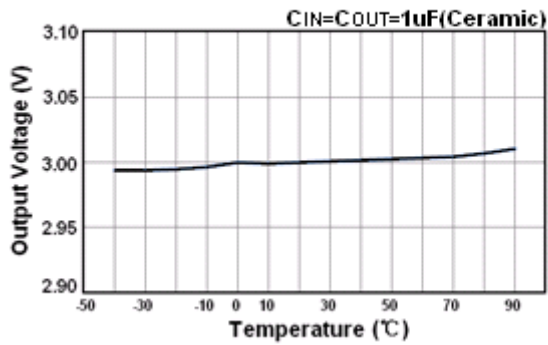

(6) PSRR

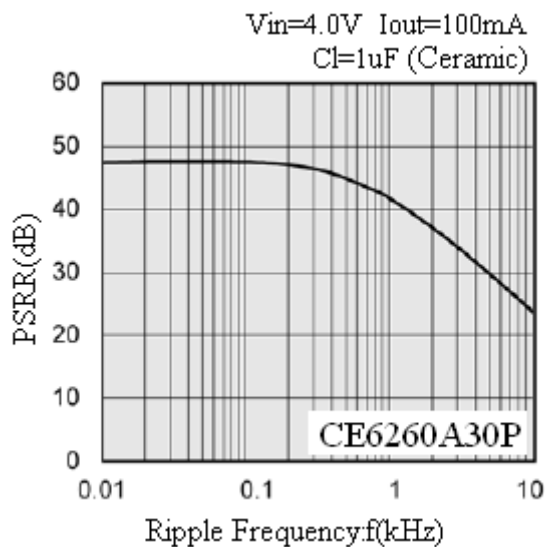

■ PACKAGING INFORMATION

● SOT-23-3 PACKAGE OUTLINE DIMENSIONS

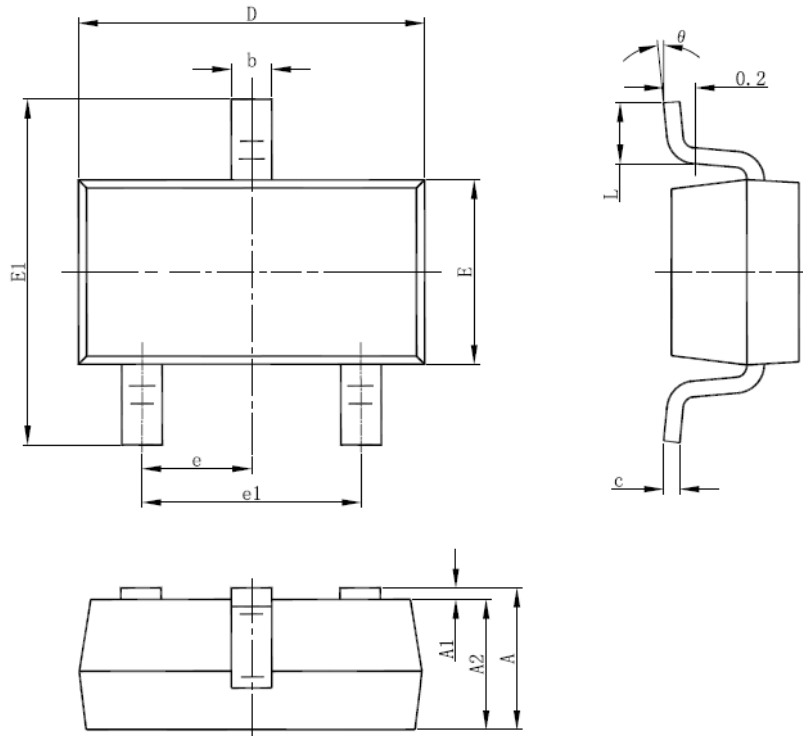

Symbol	Dimensions In Millimeters		Dimensions In Inches	
	Min	Max	Min	Max
A	1.050	1.250	0.041	0.049
A1	0.000	0.100	0.000	0.004
A2	1.050	1.150	0.041	0.045
b	0.300	0.500	0.012	0.020
c	0.100	0.200	0.004	0.008
D	2.820	3.020	0.111	0.119
E	1.500	1.700	0.059	0.067
E1	2.650	2.950	0.104	0.116
e	0.950(BSC)		0.037(BSC)	
e1	1.800	2.000	0.071	0.079
L	0.300	0.600	0.012	0.024
θ	0°	8°	0°	8°

● SOT-89-3 PACKAGE OUTLINE DIMENSIONS

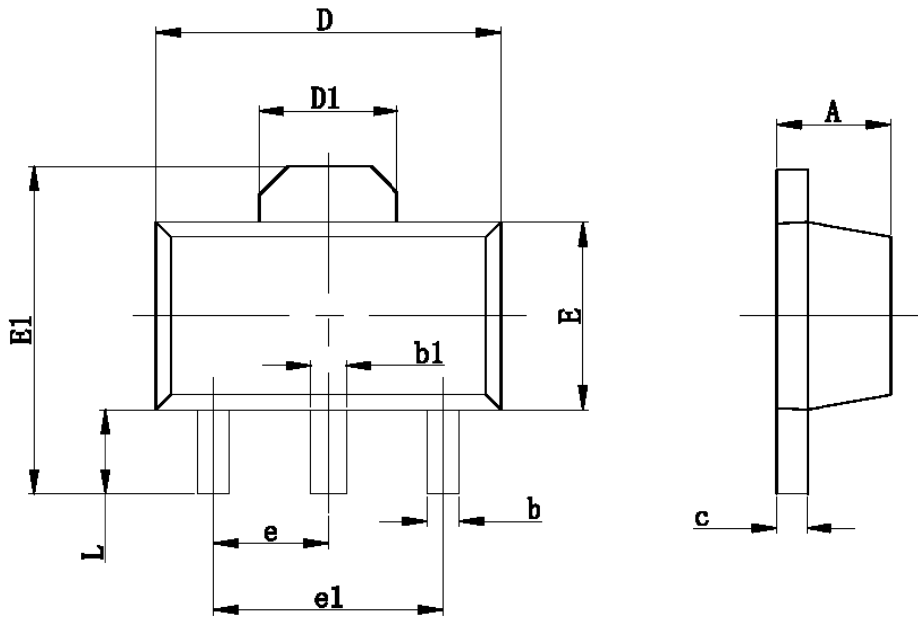

Symbol	Dimensions In Millimeters		Dimensions In Inches	
	Min	Max	Min	Max
A	1.400	1.600	0.055	0.063
b	0.320	0.520	0.013	0.197
b1	0.400	0.580	0.016	0.023
c	0.350	0.440	0.014	0.017
D	4.400	4.600	0.173	0.181
D1	1.550 REF		0.061 REF	
E	2.300	2.600	0.091	0.102
E1	3.940	4.250	0.155	0.167
e	1.500 TYP		0.060TYP	
e1	3.000 TYP		0.118TYP	
L	0.900	1.200	0.035	0.047

• SOT-23-5 PACKAGE OUTLINE DIMENSIONS

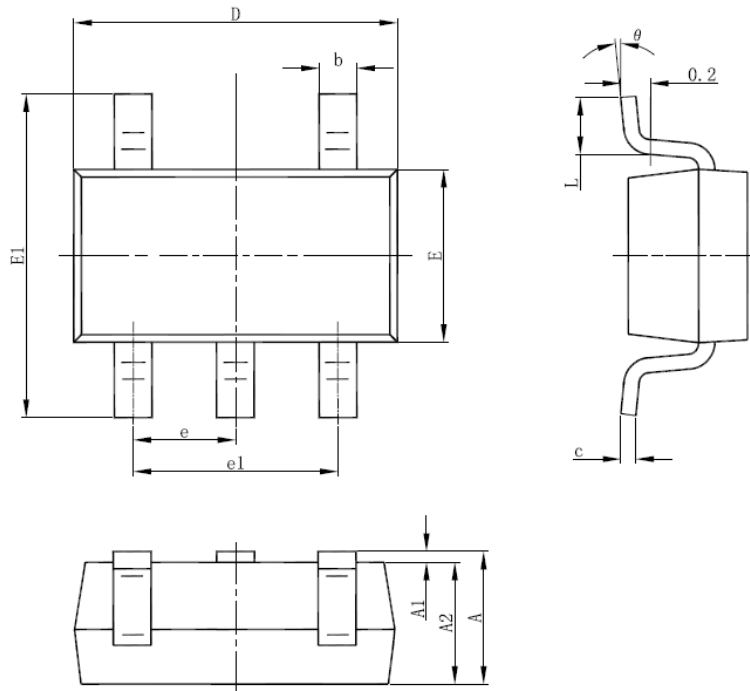

Symbol	Dimensions In Millimeters		Dimensions In Inches	
	Min	Max	Min	Max
A	1.050	1.250	0.041	0.049
A1	0.000	0.100	0.000	0.004
A2	1.050	1.150	0.041	0.045
b	0.300	0.500	0.012	0.020
c	0.100	0.200	0.004	0.008
D	2.820	3.020	0.111	0.119
E	1.500	1.700	0.059	0.067
E1	2.650	2.950	0.104	0.116
e	0.950(BSC)		0.037(BSC)	
e1	1.800	2.000	0.071	0.079
L	0.300	0.600	0.012	0.024
θ	0°	8°	0°	8°

● SOT-89-5 PACKAGE OUTLINE DIMENSIONS

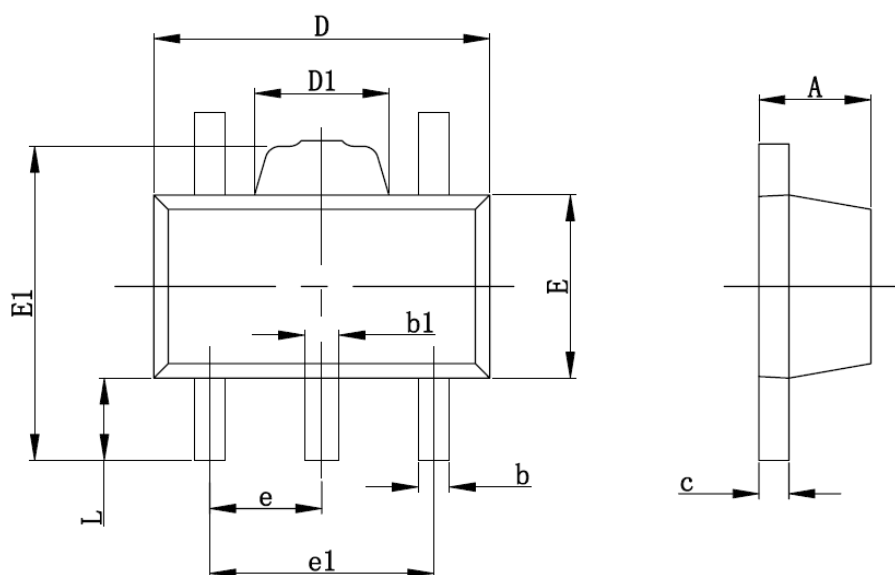

Symbol	Dimensions In Millimeters		Dimensions In Inches	
	Min	Max	Min	Max
A	1.400	1.600	0.055	0.063
b	0.320	0.520	0.013	0.020
b1	0.360	0.560	0.014	0.022
c	0.350	0.440	0.014	0.017
D	4.400	4.600	0.173	0.181
D1	1.400	1.800	0.055	0.071
E	2.300	2.600	0.091	0.102
E1	3.940	4.250	0.155	0.167
e	1.500TYP		0.060TYP	
e1	2.900	3.100	0.114	0.122
L	0.900	1.100	0.035	0.043

© Nanjing Chipower Electronics Inc.

Chipower cannot assume responsibility for use of any circuitry other than circuitry entirely embodied in a Chipower product. No circuit patent license, copyrights or other intellectual property rights are implied. Chipower reserves the right to make changes to their products or specifications without notice. Customers are advised to obtain the latest version of relevant information to verify, before placing orders, that information being relied on is current and complete.